

sigma 5

FIVE

The Sailor Pen Co., Ltd.

Robotics Division

URL : <http://www.sailor.co.jp/robotics/>
E-mail : info@robot.sailor.co.jp



■ JAPAN

The Sailor Pen Co., Ltd. Robotics Division
6-15-27 Shinmachi Ome-city, Tokyo 198-0024
TEL:81-428-31-8711 FAX:81-428-31-8717

■ USA

Sailor Automation, Inc.
981 Via Rodeo Placentia, CA 92870 U.S.A.
TEL:1-714-528-7711 FAX:1-714-528-0044
URL : www.sailorautomation.com
E-mail : support@sailorautomation.com

■ THAILAND

The Sailor (Thailand) Co.,Ltd.
89/1 Moo 5 Romklow Rd.,Klong Sampraves,
Lardkrabang Bangkok 10520 THAILAND
TEL:66-2-737-8391 FAX:66-2-360-8724

Representatives



●Please note that the specifications and other information within this catalogue may be revised without notice, due to our ongoing product research improvement efforts.

Trusted Brand

A high rigidity of the main frame and each component produce the extensive lifespan, precision, speed and repeatability with maximum flexibility to the variety of take-out part.



Air consumption is reduced by 82%
 Our new ecological design improvement achieved to reduce 82%* of the compressed air consumption. This also contributes to cutting back on the CO2 emissions.

(*compared to RZ-XII)

sigma 5

Technology

sigma 5 Series is the New Standard Extraction Robot Equipped with various functions in response to customer requests.

Durability

Safety

Operator Friendly

sigma 5 series

High Speed/High Precision Extraction Robot

Sailor Flagship Model

Safety Design

Highly Reliable Anti-Crash System (Collision prevention function)

- Take-out Dry cycle ... Less than 0.8 sec
- Dry Cycle ... Less than 5.0 sec

* In Sailor Standard Condition

Rack & pinion

Accurate & durable THK LM Guide is used for linear guide. The rack-and-pinion mechanism with special surface treatment is featured on all axis.*

The rack & pinion features high durability, excellent drive response and also maintained with their simple structure. (*excludes vertical telescopic model)

Mold change easily from 2 plate-mold to 3 plate-mold specification.

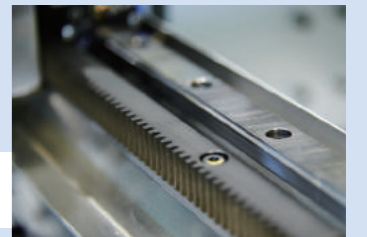

Full-Color Wide Panel

The 7-inch-wide screen touch panel controller

The colorful wide screen controller is light-weight, sleek and operator friendly.



The touch panel features a convenience-oriented User Interface.

(see next page for details)

NEXT PAGE

Mitsubishi Servo System

Mitsubishi Electric MR-J4 Series Advanced vibration suppression control II

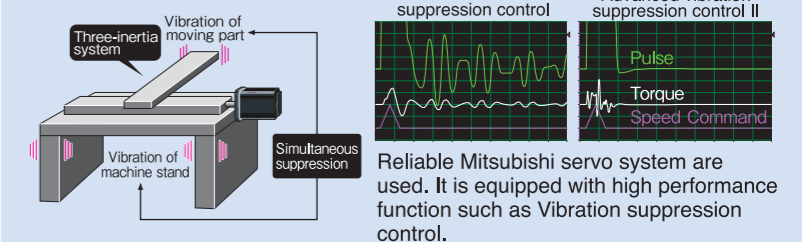

Reliable Mitsubishi servo system are used. It is equipped with high performance function such as Vibration suppression control.

Automatic Vibration Suppression Control (VSC)

The Vibration Suppression Control lowers the vibration of take-out arm by tuning for each load.

Cross Section of Horizontal Frame



The horizontal frame made with optimal sectional shape gives it a high rigidity profile.

Traverse Frame Structure



Composed by rigid material and structure. Designed for long lifespan and high durability.

Operator Friendly

Large Screen Touch Panel

7-inch-wide color screen with WVGA (800X480) and 260,000 colors. We improved the resolution further with easy-to-identify icons, a touch switch with consideration to recognition, and a proper screen layout ensure reliable operability. Available to set up 5 axes in one screen, access and switch to any other screen instantly through the menu bar.

Multilingual

The language display supports 6 languages of Japanese, English, Korean, Thai, Chinese and Spanish. Language Optional except for Japanese and English.

Wireless Function

Wireless communication with the handy pendant becomes possible by installing a wireless unit in the pendant. Because it's a wireless, adjustment of position, timer, speed, etc. can be done from non-operator side easily. One (1) wireless pendant can control multiple robots.

Touch Panel Controller



USB Port

The pendant equipped with two USB ports. Saving the mold data, alarm/operation history improves your factory productivity and process control. (USB memory stick not included)



Cross-Keys

Utilizes Responsive Directional Control. It can control and operate each axis of the robot while teaching. Same cross-keys also show on the touch screen.



Main Menu Screen

A new design of easy identify icons layout. Touch switches identified by color and shape with its different function in all screen.

Function List

MyPro Function

When in need for a unique, outside of the default movements (pick and place position, timer, input/output), you can use the MyPro function to program your specific movements step by step. Able to setup Part-arm and Runner-arm separately, able to repeat number of times in-between steps.



Name Edit Function

Default names of teaching data and timer can be edited using screen keyboard. For factory who utilizes two or more different robots, change and unify the name of positions and timers should help operator for their easier recognize.



Help Function

Display the operator's manual. Includes help comments, handling explanation, trouble shooting and operation instructions. (pdf format)



Screen Memo

A display screen can be copied to a USB memory as a screen shot.



Mold Data

Your important mold data can be saved by an easy organize File Manager Form. Available to input additional information regarding the mold. This mold data saving function plays a role for mold changing and is useful for improving efficiency.



Login Function

One administrator and ten (10) users can be registered. Five stages of operation level can be set to each specific user. *2 stages setup of operation level is standard.

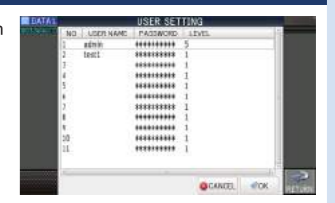

Ten Key/Collision Prevention

The easy view display of each axis and setup range is organized for trouble-free operation. Input settings with the 10 key numerical pad. In addition, adjustment of the first digit can be easily set by the up/down keys. The Collision prevention function with the ability to automatically calculate the max/min values and alert operator to prevent collision when teaching.

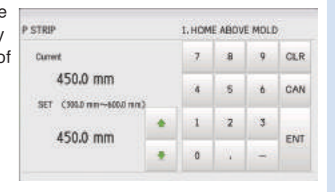

Simulation Function

The content of the condition Teach setting is displayed in animation. Operation speed is adjustable by four stages. Simulation function brings you the operating confirmation, it is useful for preventing misconfiguration.



Alarm/Operation History

Alarm history and other log-in operating history records display are easy-view. To copy this record on to a USB driver is also possible. Operating log-in screen is optional, setup freely.

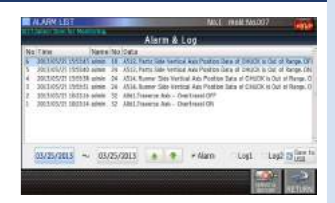

VNC Function

Virtual Network Computing (VNC) Function enable to check monitor and setting of the extraction robot via network.

Model Identification

S5 - 50

Series Clamping Tonnage of Target Injection molding machine



No. of vertical guides

S : Single Arm
W : Double Arm



Unloading Direction

R : Operator Side
L : Non Operator Side



Type of vertical guide

No indication means Standard(single guide)
T : Telescopic Type with double guides

Measurement unit:mm

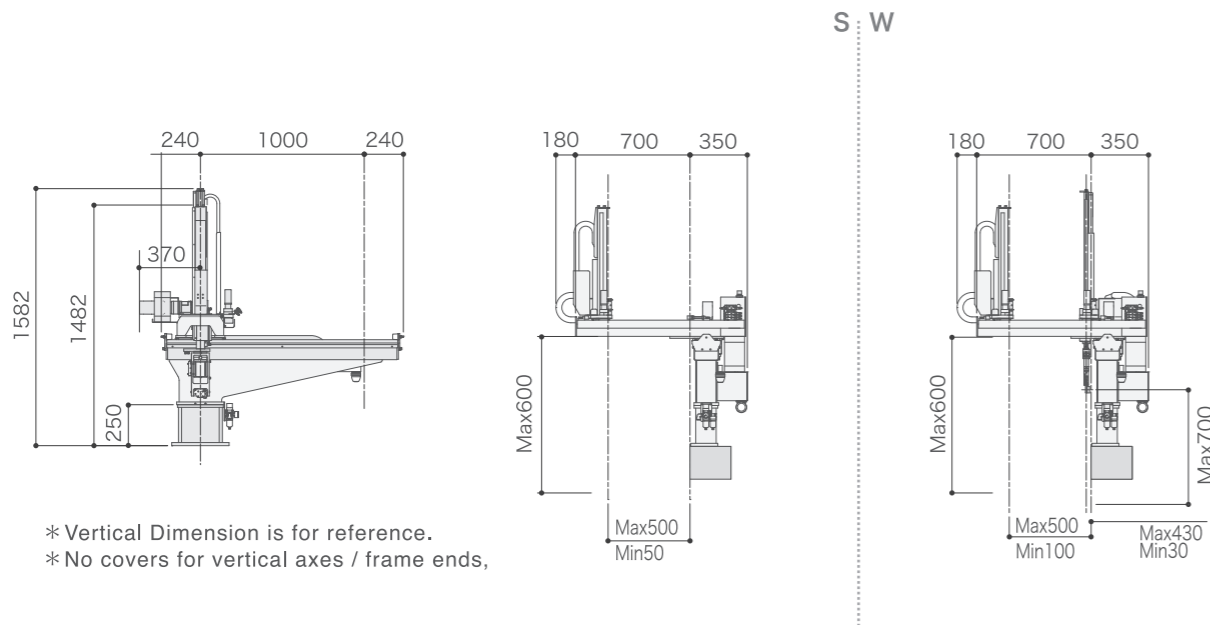

Specification

Energy Consumption	4.04 kWh (per 1hour)	Maximum Air Pressure Capacity	0.97 MPa
Power	AC200V±10% 50/60Hz 3φ	Drive System	AC Servo Motor
Max Power Consumption	3~6 kVA	Accuracy of Repeatability	±0.1mm
Normal Air Pressure	0.5~0.6 MPa	Maximum Loading Capacity (including a chuck weight)	5kg (with standard strokes & ThinA12 type wrist turn unit)

*Maximum loading capacities are our recommended value. Higher load than the indicated values are also possible with the adjustment of the operation speed.

Model Identification

S5 - 100

Series Clamping Tonnage of Target Injection molding machine



No. of vertical guides

S : Single Arm
W : Double Arm



Unloading Direction

R : Operator Side
L : Non Operator Side



Type of vertical guide

No indication means Standard(single guide)
T : Telescopic Type with double guides

Measurement unit:mm

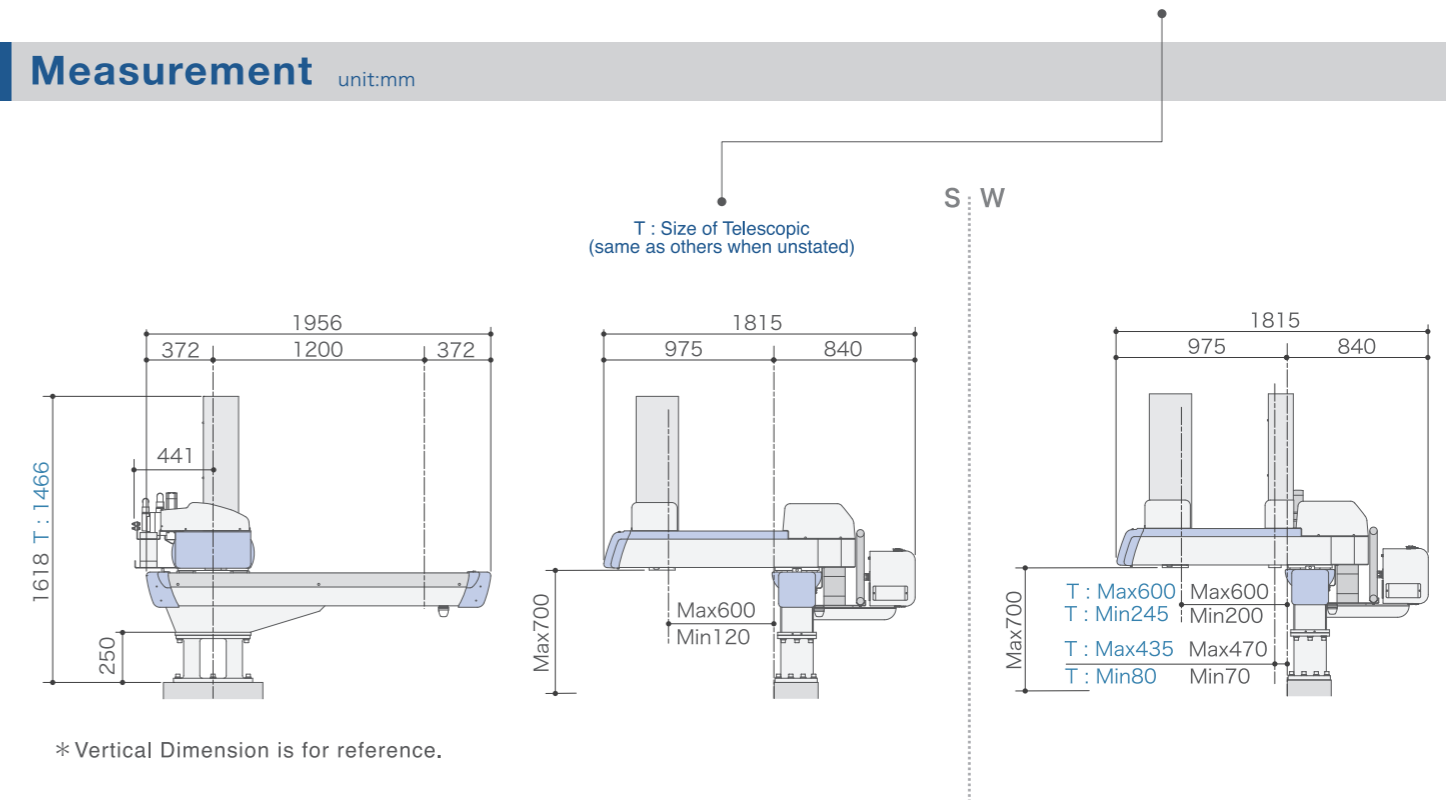

Specification

Energy Consumption	4.04 kWh (per 1hour)	Maximum Air Pressure Capacity	0.97 MPa
Power	AC200V±10% 50/60Hz 3φ	Drive System	AC Servo Motor
Max Power Consumption	3~6kVA	Accuracy of Repeatability	±0.1mm
Normal Air Pressure	0.5~0.6 MPa	Maximum Loading Capacity (including a chuck weight)	10kg (with standard strokes & ThinA12 type wrist turn unit)

*Maximum loading capacities are our recommended value. Higher load than the indicated values are also possible with the adjustment of the operation speed.

S5-200

S5-300

Model Identification

S5 - 200

Series

Clamping Tonnage of Target Injection molding machine



No. of vertical guides

S : Single Arm
W: Double Arm



Unloading Direction

R : Operator Side
L : Non Operator Side



Type of vertical guide

No indication means Standard(single guide)
T : Telescopic Type with double guides

Measurement

unit:mm

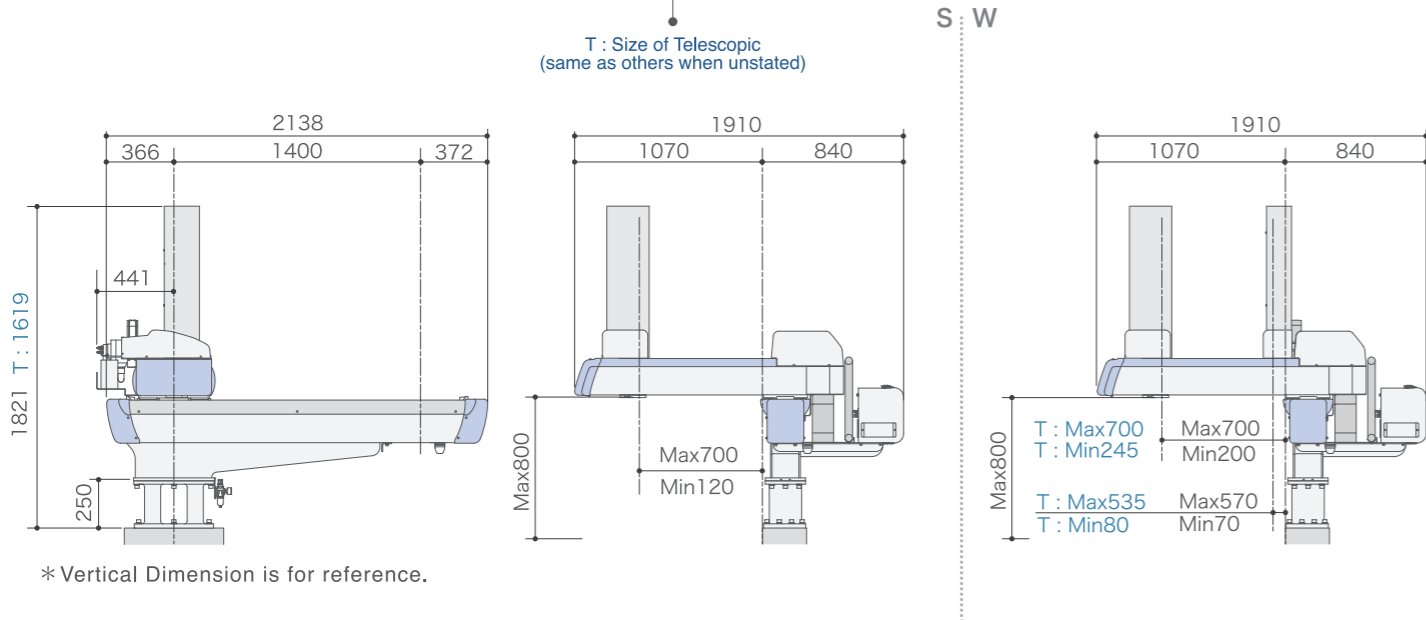

Specification

Energy Consumption	4.04 kWh (per 1hour)	Maximum Air Pressure Capacity	0.97 MPa
Power	AC200V±10% 50/60Hz 3φ	Drive System	AC Servo Motor
Max Power Consumption	3~6kVA	Accuracy of Repeatability	±0.1mm
Normal Air Pressure	0.5~0.6 MPa	Maximum Loading Capacity (including a chuck weight)	10kg (with standard strokes & ThinA12 type wrist turn unit)

*Maximum loading capacities are our recommended value. Higher load than the indicated values are also possible with the adjustment of the operation speed.

Model Identification

S5 - 300

Series

Clamping Tonnage of Target Injection molding machine



No. of vertical guides

S : Single Arm
W: Double Arm



Unloading Direction

R : Operator Side
L : Non Operator Side



Type of vertical guide

No indication means Standard(single guide)
T : Telescopic Type with double guides

Measurement

unit:mm

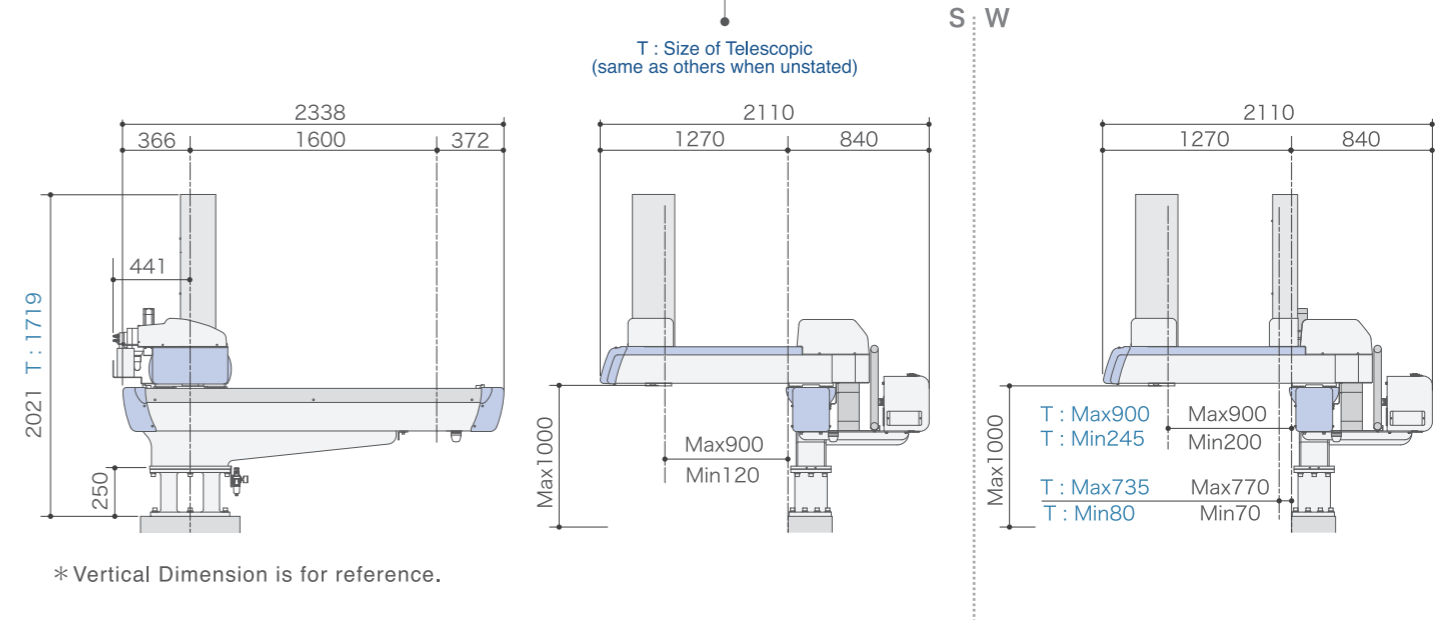

Specification

Energy Consumption	4.04 kWh (per 1hour)	Maximum Air Pressure Capacity	0.97 MPa
Power	AC200V±10% 50/60Hz 3φ	Drive System	AC Servo Motor
Max Power Consumption	3~6kVA	Accuracy of Repeatability	±0.1mm
Normal Air Pressure	0.5~0.6 MPa	Maximum Loading Capacity (including a chuck weight)	10kg (with standard strokes & ThinA12 type wrist turn unit)

*Maximum loading capacities are our recommended value. Higher load than the indicated values are also possible with the adjustment of the operation speed.

1 Flip-Turn Unit (Thin A12)

As the chuck stays standing up when taking out the parts from the mold, this unit is used to turn the chuck downward and then place the parts on a conveyor or auxiliary equipment.
The direction of the rotation axis is in horizontal.

2 Parts Vacuum Suction Detect Circuit

An air circuit, which consists of a vacuum generator (ejector) for suctioning the parts, and a related piping, and a pressure gauge, etc.

3 Parts Mechanical Chuck Circuit

An air circuit for mechanically holding the parts which consists of compressed air piping, solenoid valve, etc.

4 Orientation Control Position Setting

Setting of a position where Orientation control is performed for flip-turn and pivot-turn.

5 Priority Settings for Parts Reject/Runner Reject Position, and Vertical Position

Setting of the places and orders for dropping defective parts, runner and etc., for example, into a crusher.

6 Runner Traverse Discharge (Before or After Parts Unloaded)

Runner is discharged during a traverse stroke.

7 All Axis Parts Palletizing (999 positions for each axis)

For traverse axis, strip axis and vertical axis, palletizing of the parts at the maximum 999 positions is available for each axis.

8 Strip Axis/Traverse Axis Shift Palletizing

Setting of shift palletization for each strip axis and traverse axis.

9 Traverse Secondary Home Setting

In the case of a mold that has a motor placed on the top of the mold, for example, the traverse axis returns above the mold after waiting on the way while molding is proceeding.

10 Teaching Data Check Function

A function that a value more than the stroke cannot be entered.

11 Login Function

A function that only a registered person can log in and operate the system.
As standard, two stages of operation levels can be defined.

12 Undercut Release Servo Operation

For an undercut mold, a servo motor is used to release the undercut.

13 Initial Reject Quantity

A function that only the predefined number of the parts initially be rejected.

14 NG Parts Reject/Overflow Reject

A function that when an interlock from an auxiliary equipment is not released after NG signal is received from IMM, the parts is rejected.

15 Shutdown Circuit After Consecutive NG Rejects

A function that the system is shut down after the predefined number is reached, when NG parts continuously occurs and overflows.

16 Auxiliary Equipment Interlock Setting

Setting for interlocking with an auxiliary equipment such as inspection device and stock device. Including the supply of the molded parts by STANDBY OK signal of an auxiliary equipment or AUXILIARY EQUIPMENT START signal and etc.

17 Vertical Axis - Proximity to Mold Halt

A function that the vertical axis moves down up to the vicinity of the mold from the uppermost in order to wait for the mold to open before the mold opens.

18 Original Optimize Movement

A function to enable quick and smooth movement in a curve-like fashion.

19 Detailed Display of Operations History and Data Storage

A function that operations history is recorded and displayed, and these data can be saved in a USB memory.

20 Maintenance Period Setting, Alarm Indication

A function that maintenance period is specified and alarm is indicated.

21 Position Teaching While Auto Mode in Execution (Max. ± 3 mm)

Fine tuning of a position can be executed while the system operates in auto mode.

22 Energy Saving Operation

A function that the system operates at the speed automatically lowered in the range of the cycle to reduce the load on a take-out robot.

23 Sampling Mode

A function for unloading the parts at a sampling position.

24 Production Control Mode

When the predetermined number is reached the buzzer, for example, sounds to shut down the operation.

Descriptions of Standard and Optional Specifications

Standard Specification Description

25 MyPro Function

Arbitrary positions (Position, Timer, Input/Output) can be added and edited in Step unit. In addition, the operation of parts arm and runner arm can be individually defined, and the created Steps can be repeated in a specified number of cycles.

26 Control Box Internal Temperature Monitoring

The temperature in the control box is monitored.

27 Ecological Vacuum System

Air consumption is reduced by 82 % compared with previous system.
This also contributes to cutting back on the CO2 emissions. (*compared to RZ-ΣII)

Optional Specifications Description

*1 to 14 are equipped with an operation program as standard.

1 AIII, AB and D Flip-Turn Units

Flip-turn unit can be selected according to the size, weight, and necessary movement of the chuck.

2 Parts Vacuum Circuit (1-4 Lines)

The vacuum circuit can be increased to the maximum of 4 lines.

3 Vacuum Break Circuit (1- 4 Lines)

In order to facilitate taking out the parts when releasing them, a vacuum break circuit can be also installed in accordance with a vacuum system.

4 Pivot Turn/Turn Position Setting

By installing a pivot-turn unit, the chuck can be pivot-turned in a vertical direction. (The direction of the rotation axis is in vertical) In addition, this function is provided to set the position where the vertical turn is executed.

5 Parts Runner Vacuum Circuit

A vacuum circuit for suctioning a runner into the parts chuck.

6 Parts Unload 4-Position (with Vertical Shift Function)

In one single shot, the parts can be individually placed at four different places. Vacuum lines according to the number of unloading parts are required.

7 Beam-End Gate Cut 4-Position Cycle

Beam-end gate cut operation can be individually executed at four different places in one single shot.
*Beam-end gate cut unit is required.

Optional Specifications Description

*1 to 14 are equipped with an operation program as standard.

8 Beam-End Gate Cut Direction Setting for All Axes

Cutting direction at the beam-end for all axes can be defined.

9 Gate Cut Unload Position in Chuck or Traverse On-The-Way Position

Cutting position can be defined by using the chuck with a pair of nippers installed in the chuck.

10 Pitch Change in Chuck

The pitch of the parts can be changed by using a chuck that has a pitch change function installed.

11 Undercut Release Air Operation

For an undercut mold, air cylinder is used to execute undercut release operation.

12 Extension of Vertical, Horizontal, and Traverse Stroke

The stroke for each axis can be extended.
Note) The stroke for traverse axis is in increments of 200mm.

13 Blower Specification

This specification is provided to use blower chuck and blower motor so that small parts or complicated shape parts, or cylindrical parts incapable of holding by suction cups can be suctioned with a large volume of vacuum force. (Ex. Ball-point pen axis)

14 Parts Vacuum Circuit Multiple Systems (More than 5 systems. The software is not for standard)

This specification is provided to use energy saving vacuum circuit so that compared to standard specifications, the amount of compressed air used can be reduced, and the power consumption also is significantly lowered.

15 Controller Stand

A stand to place the handy controller (touch panel).

16 Wireless Function

Wireless communication with the handy pendant becomes possible by installing a wireless unit in the pendant. Because it's a wireless, adjustment of position, timer, speed, etc. can be done from non-operator side easily. One (1) wireless pendant can control multiplerobots.

17 Telescopic Specification

Two-tier structure makes it possible to keep the maximum height of the system low for the same upper and lower strokes.

18 VNC Function

Virtual Network Computing (VNC) Function enable to check monitor and setting of the extraction robot via network.

19 Clean Room Specification

This specification is provided to use the controller in a clean room by installing a tray on the part where dust possibly occurs, or by covering the surface with stainless steel.

Floor Type Control Box

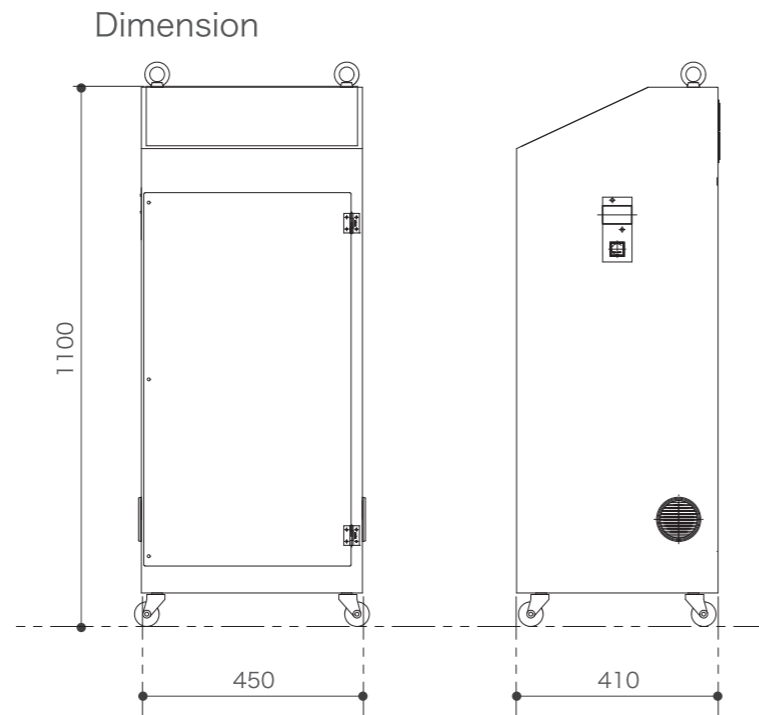

*Dimension of standard type.
(depending on model and specification)

For your safety(Domestic Law in Japan)

This system corresponds to an "industrial robot". To use it, participation in "Special Training on Operations of Industrial Robots" (*) legally prescribed is required.
In addition, risk assessment should be executed at the installation site, and safety measures such as installing fences should be taken.

*This training is also held in Ome Factory of Robotics Division in The Sailor Pen Co., Ltd.
For more information, please see the website of this division.
*Refer to the law in which country the machine is installed.

Two-Head Specification

This specification is provided to respond a two-color molding machine by using a system with two heads for primary take-out and secondary take-out.

Insert (In-Mold) Specification

This specification is provided to use a chuck with insert function for insert operation.
It is possible to insert a workpiece such as a metal or film in the mold, and also to take out the workpiece.

Telescopic Specification

Two-tier structure makes it possible to keep the maximum height of the system low for the same upper and lower strokes.

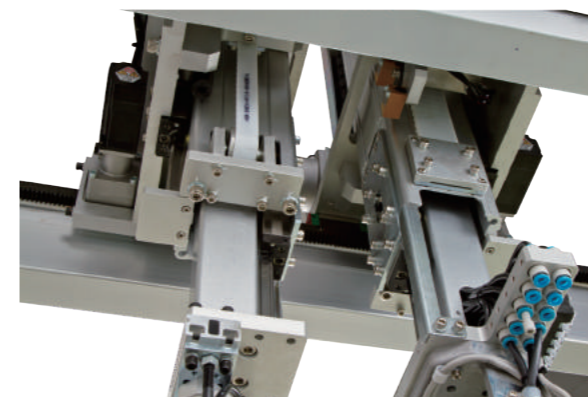

T-Shaped Specification

This specification is such that the arm extends on both the molding machine operation side and the non-operation side.
For example, it is possible to place a part on the operation side and to drop a runner on the non-operation side.

Blower Specification

This specification is provided to use blower chuck and blower motor so that small parts or complicated shape parts incapable of holding by suction cups can be suctioned with a large volume of vacuum force.



S5-50
Blower Specification

Servo Chuck Turn

This specification is provided to use a servo motor for rotating a chuck. Teaching by means of the touch panel makes it possible to operate the chuck at any angle.

Stack Specification

This specification is provided to install a parts chuck on the two arms one by one for parts take-out operation.



Other Extraction Robots

Swing Type Picker RX-8

Simple swing type sprue picker. Simple structure without motor has high rigidity and high cost performance.
Applied for 50-150 ton injection molding machine.



Controller



Handy type pendant controller with Japanese/English Indication. (also Thai, Korean, Chinese can be chosen.) Pictgrams make operation easier.

- Controller with one chip microcomputer
- Enable/Disable Switch
- Alarm history display (5 items)
- Mold setup memory
- Backlight liquid crystal display
- Lightweight, compact pendant body
- Confirmation operation
- Alarm message display
- 2nd machine interlock as a standard feature

Standard Specification

Power Supply	DC24V
Maximum Electric Power Requirement	20W
Normal Air Pressure	0.5~0.6 Mpa
Maximum Air Pressure	0.97 Mpa
Actuating method	Air cylinder
Control system	Microprocessor

Dimensional Drawing

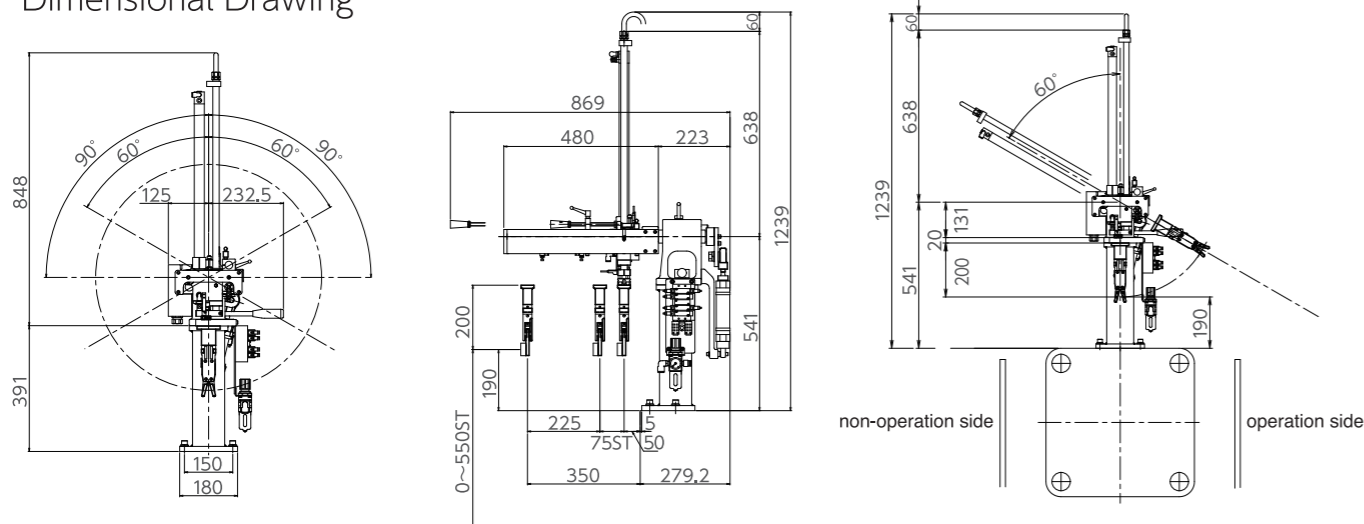

Model Name	Molding Machine (tons)	Cylinder (without oil supply)			Press Capacity				Main Unit Dimensions (mm)	Weight (Kg)	Air (NL/cycle)
		Vertical	Strip	Swing	Vertical	Strip	Horizontal	Swing Angle			
RX-8	50-150	Ø25 550st	Ø20 75st	Ø40 100st	0-550	0-75	50-225	60° -90°	H1239(-1139) W357.5 L864	39.5	12

Swing Robot

High Speed Swing Robot for CD manufacturing. Also can be used for sprue picking of small injection molding machine.



Ultra High Speed Extraction Robot

Extraction robot specialized for very short cycle time. New material such as CFRP* used for each axis to reduce weight and high power motor makes extraordinary speed possible.

- Take-out Dry Cycle ... Less than 0.4 sec
- Dry Cycle ... Less than 2.2 sec

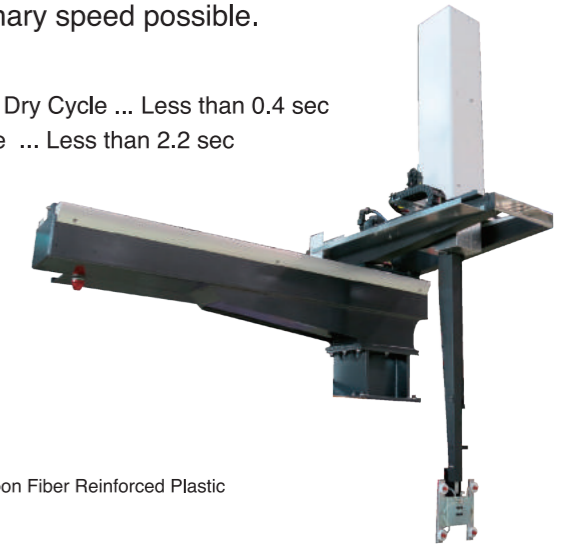

*CFRP:Carbon Fiber Reinforced Plastic

Injection Molding Machine Tonnage	50	100	200	300
Vertical Stroke	600	700	800	1000
Traverse Stroke	1000	1200	1400	1600
Maximum Horizontal Position	500	600	700	900

Unit : mm

Take-out Chuck (End Of Arm Tool)

We design Special Chuck for your product.

Chuck with pitch adjustment

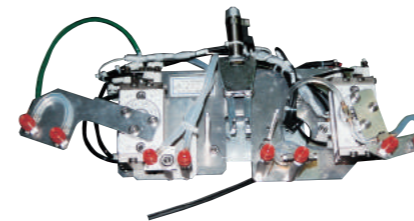

Chuck with adjustment unit for different product position between mold and placing. Movement for product position/rotation change can be chosen. Also can be designed according to mold opening and design.

Mechanical Chuck

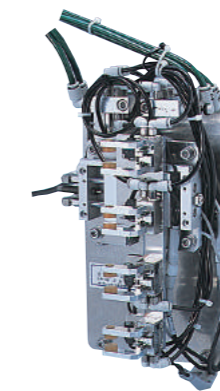

Mechanical chuck need to be designed carefully about the chucking position and detection method if you need to chuck complex product. Special claw, pad, etc. can be selected.

Insert Chuck

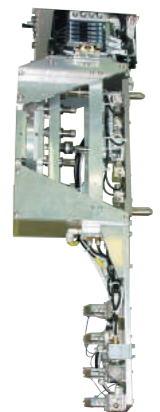

Insert unit and chuck for insert metal or insert label.